

FAG HYDNUT480-INCH参数

尺寸	d_{2G}	479.908	mm	-
	D_m	612	mm	-
	b_1	76	mm	-
说明		476.860	mm	节圆直径
		476.86	mm	节圆直径
		18	mm	行程
尺寸	D_K	560	mm	-
	d_K	482	mm	-
	g	12	mm	-
重量	m	63000	g	质量, 液压螺母
说明		460	cm	活塞面积
		3680	kN	压紧力 800bar
		5		每英寸的螺纹数

FAG HYDNUT480-INCH图片

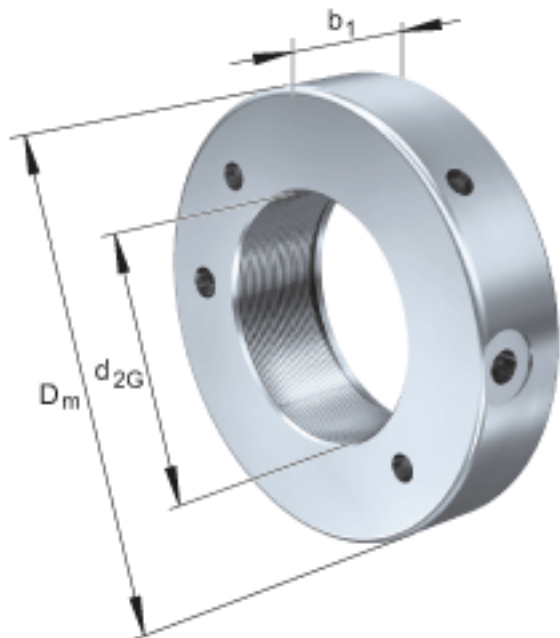

参考资料:<http://www.sozhou.com/p/dd9c920b.html>

