

FAG HYDNUT320-INCH参数

尺寸	d_{2G}	319.075	mm	-
	D_m	430	mm	-
	b_1	63	mm	-
说明		316.324	mm	节圆直径
		316.324	mm	节圆直径
		14	mm	行程
尺寸	D_K	389	mm	-
	d_K	322	mm	-
	g	10	mm	-
重量	m	29900	g	质量, 液压螺母
说明		264	cm	活塞面积
		2112	kN	压紧力 800bar
		6		每英寸的螺纹数

FAG HYDNUT320-INCH图片

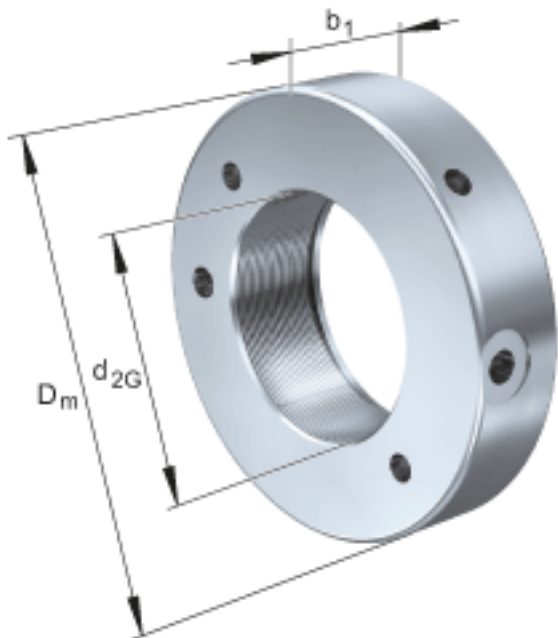

参考资料:<http://www.sozhou.com/p/e6fd1bf5.html>

